

Jodie Brown

From: Neil Neil <nlboler@hotmail.com>
Sent: Tuesday, 17 May 2022 3:37 PM
To: Jodie Brown
Subject: Re:BA.DA 40/2021

Hi Jodie,

Please be advised that I wish to change the proposed use or development of Pn 35f5 from:

1. Relocatable cabin to an uninhabited shed.
2. Delete the above ground pool and deck, which have been dismantled.

Regards
Neil

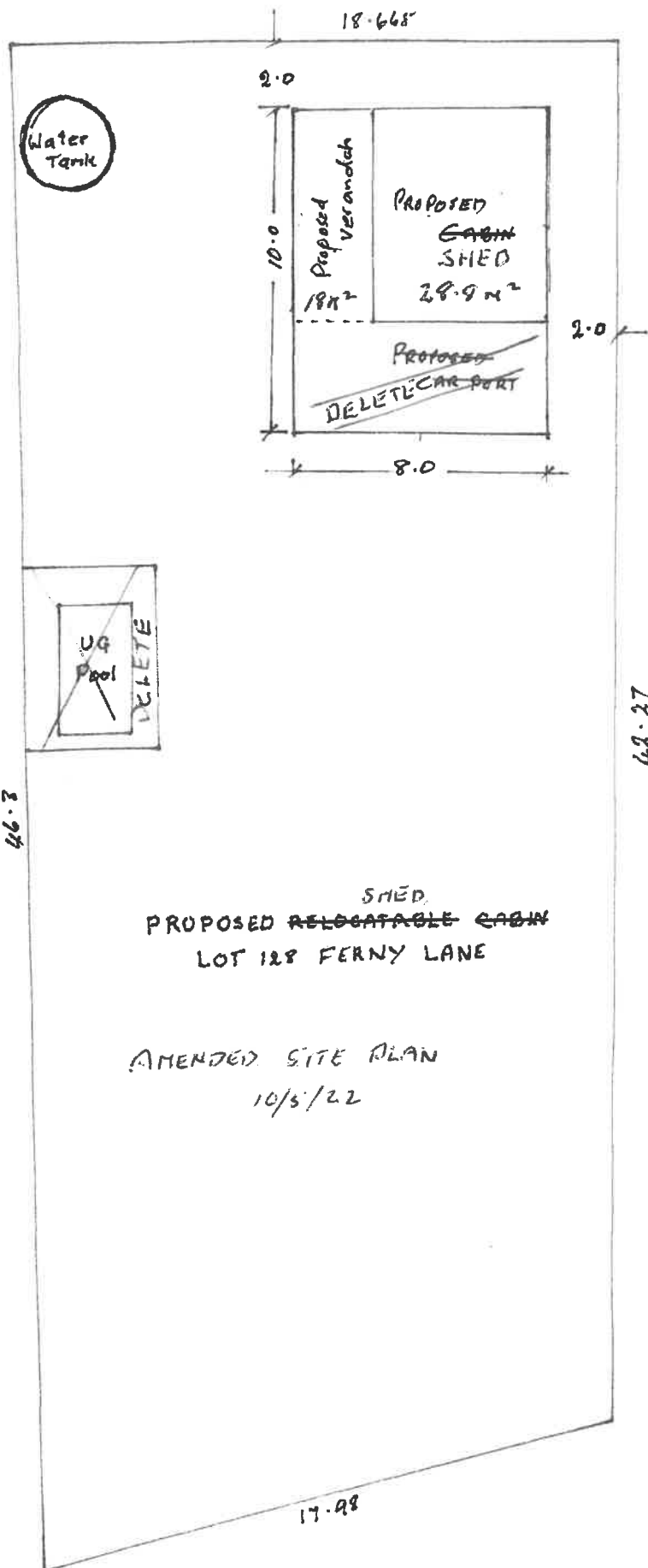

SITE PLAN
FERNY LANE

LOT 128
SECTION 27
PORTION 35F5
AREA 800 M²

SHED
PROPOSED RELOCATABLE SHED
LOT 128 FERNY LANE

AMENDED SITE PLAN
10/5/22

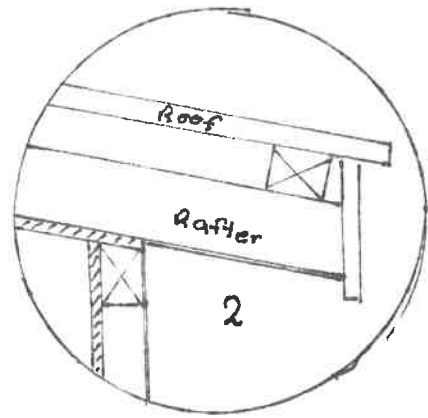
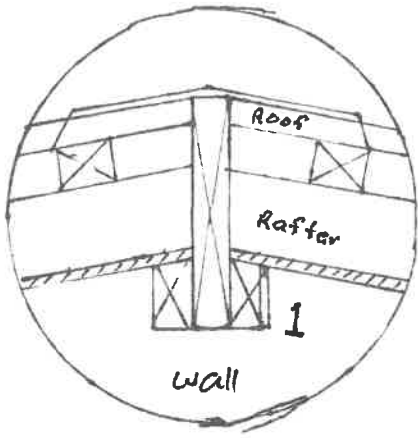

9.8

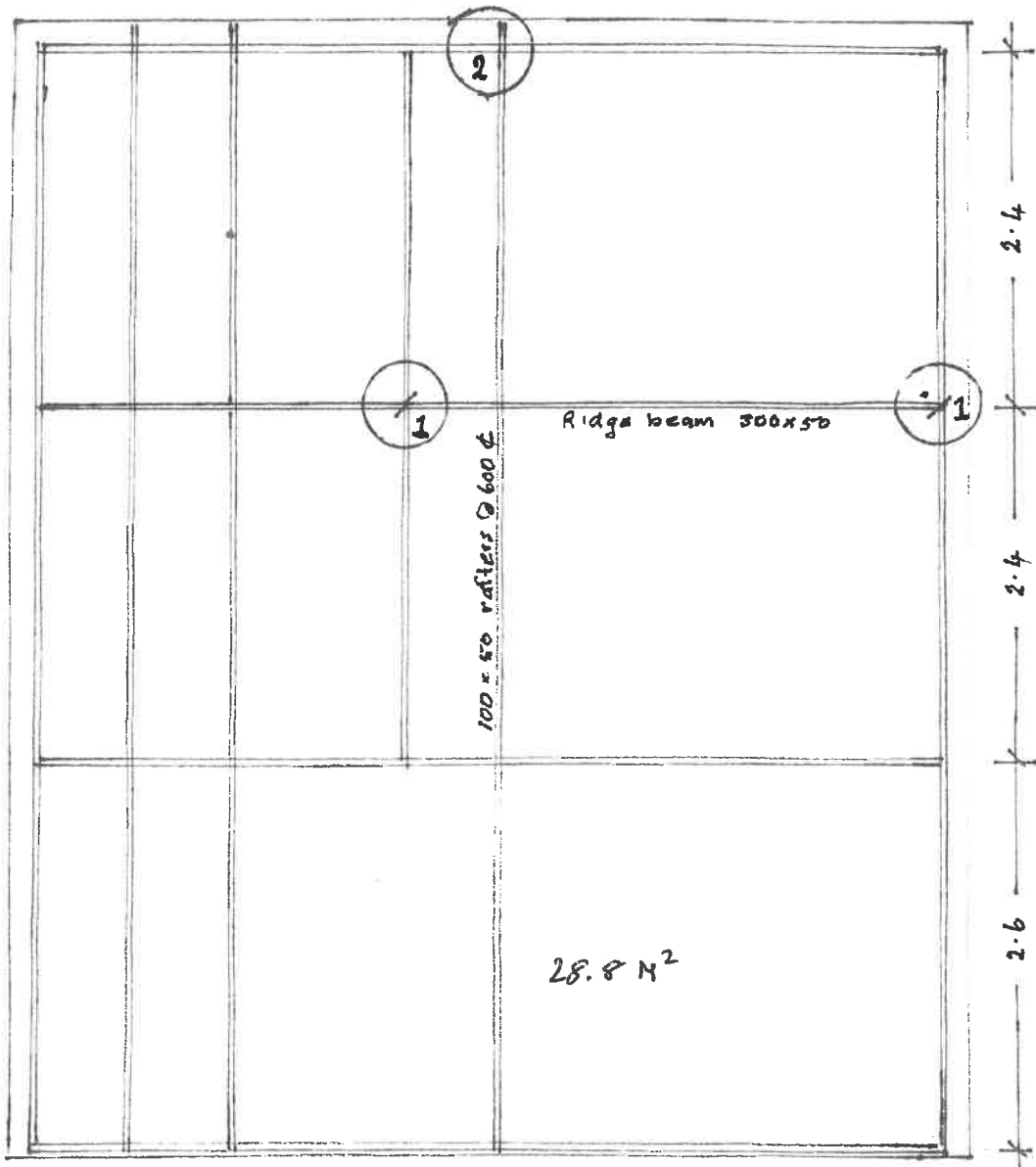

AMENDED 10/5/22

ROOF PLAN

PROPOSED ~~RELOCATABLE~~ ^{SHED} CABIN

LOT 128 FERNY LANE

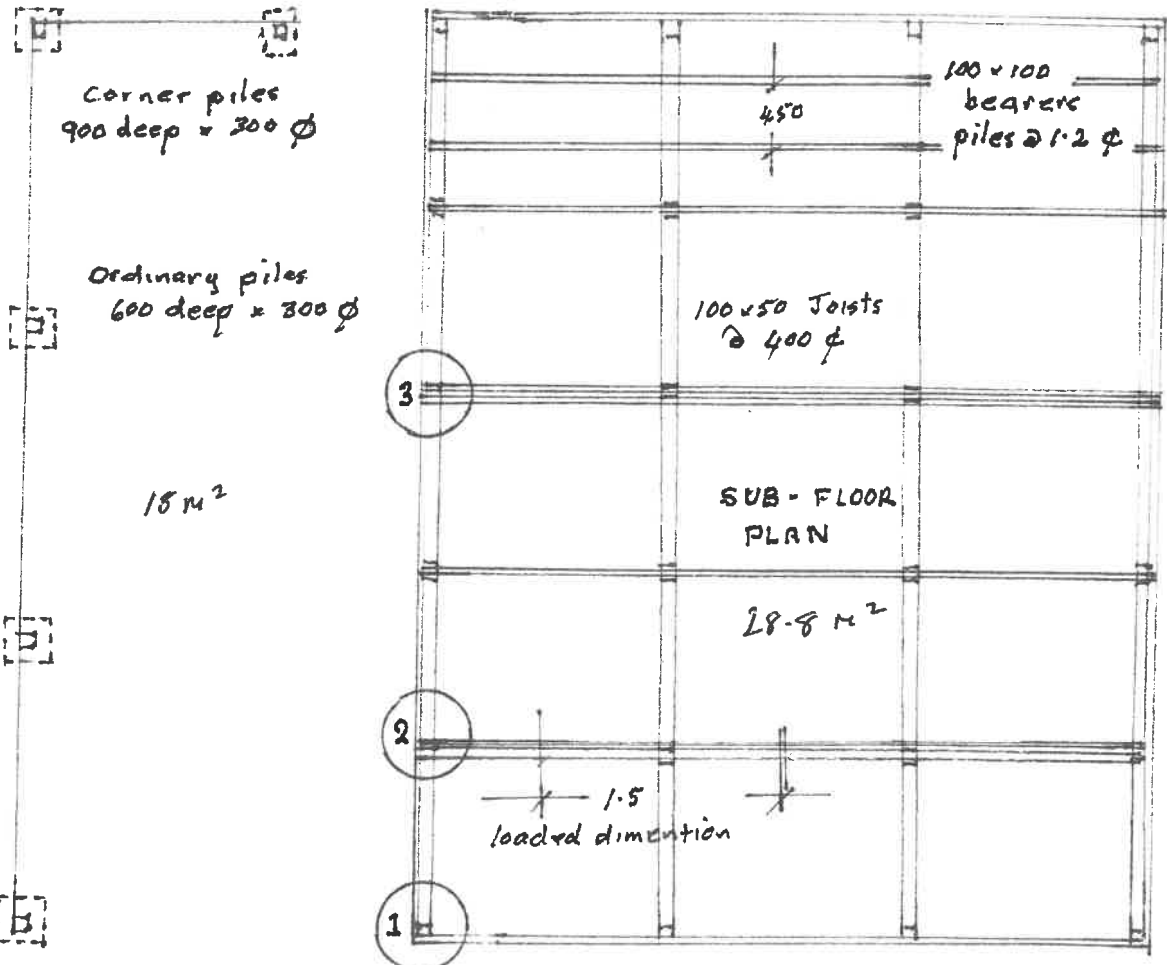
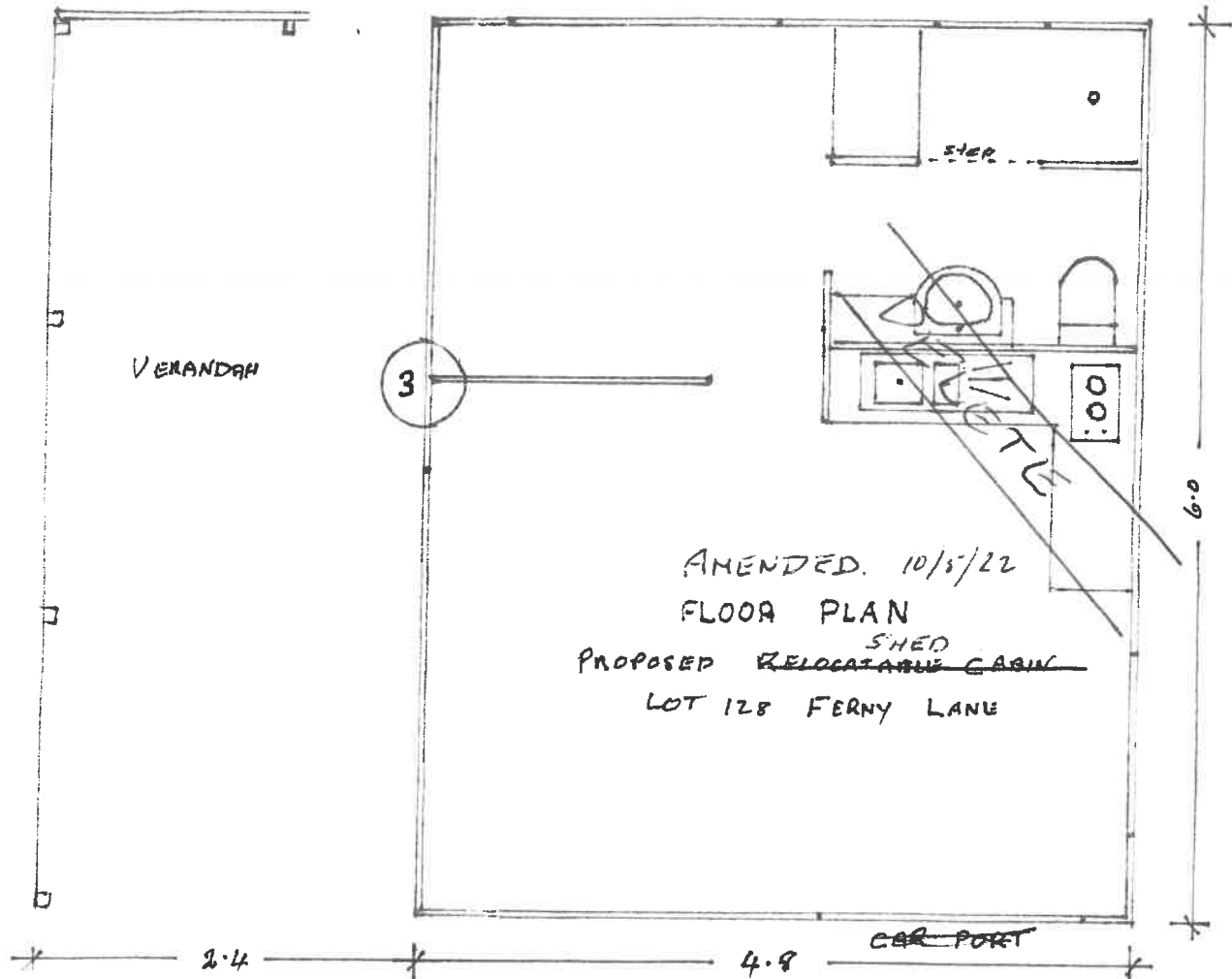

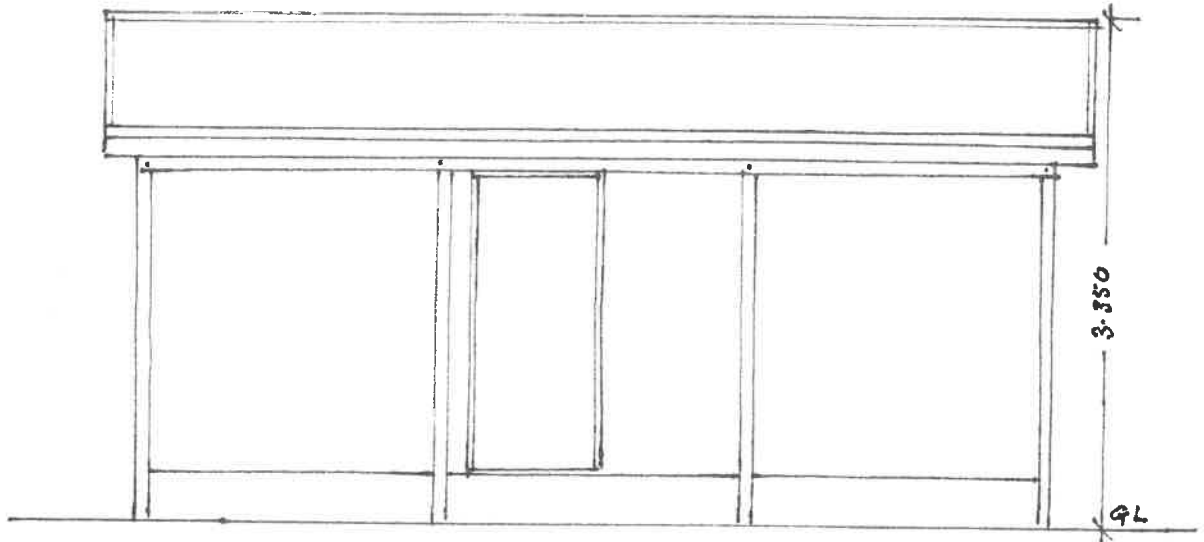

SIDE ELEVATION

~~PROPOSED RELOCATABLE CABIN~~
^{SHED}
LOT 128 FERNY LANE

AMENDED ELEVATIONS 10/5/22

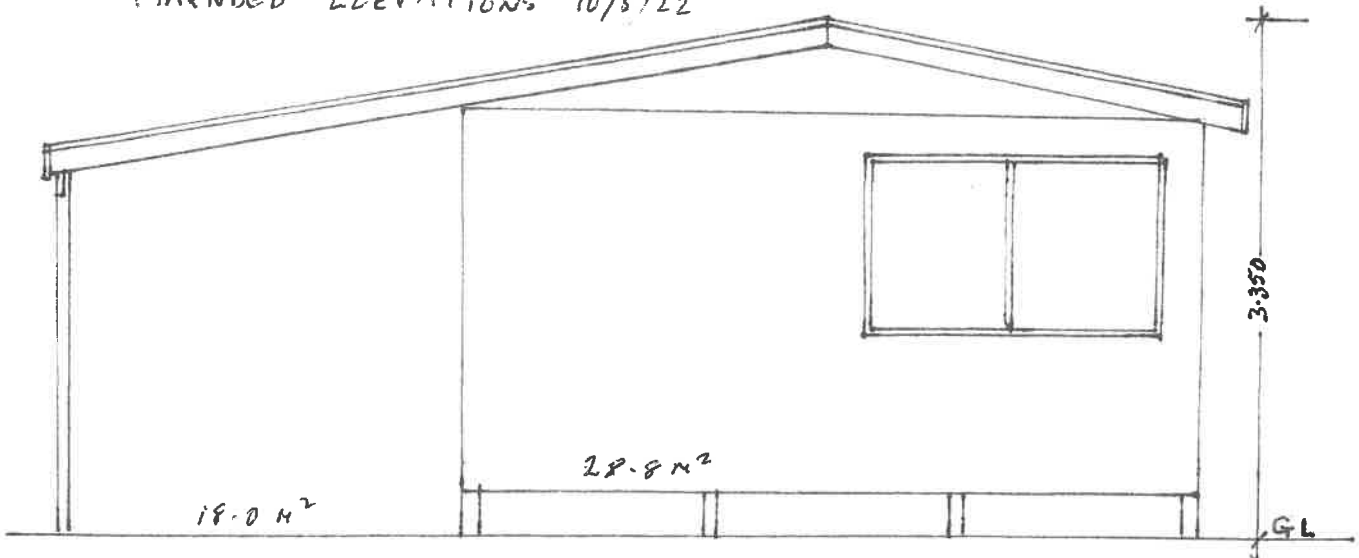

END ELEVATION